

Machine Safeguarding

When the operation of a machine or accidental contact with it could injure the operator or others in the vicinity, the hazards must be either controlled or eliminated. Moving parts at the point of operation, in the power transmission apparatus, or any other parts of the machine that move require safeguarding. Equipment must be evaluated for the following dangerous motions and actions:

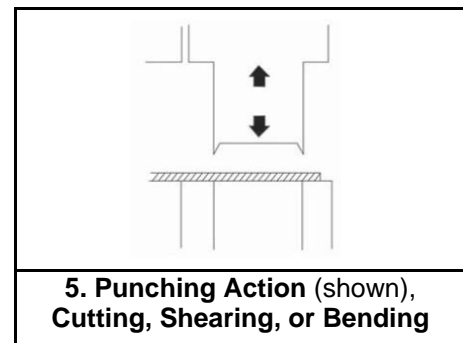
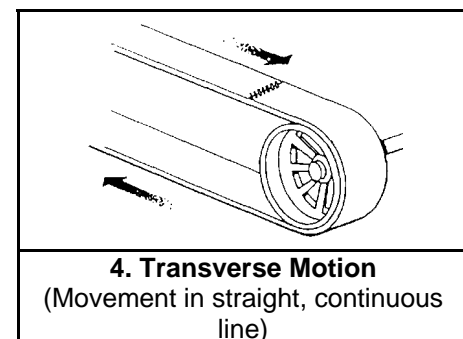
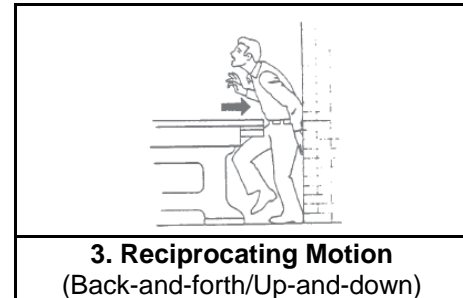
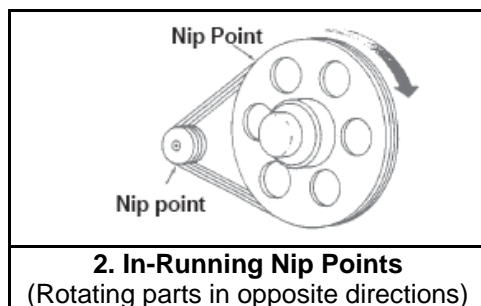
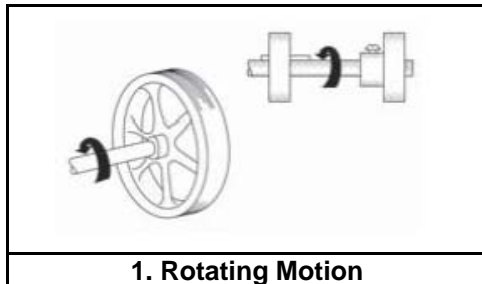

Machine guarding decisions should be made in the following order of preference:

- Design out or eliminate the hazard
- Guard the hazard
- Use warning devices or signs
-

Use safe working practices and procedures

The Experienced
Workers'
Compensation
Specialist

Safeguards must meet these minimum general requirements:

1. **Prevent contact:** A good safeguarding system eliminates the possibility of the operator or another worker placing parts of their bodies near hazardous moving parts.
2. **Secure:** Operators should not be able to easily remove or tamper with the safeguard.
3. **Protect from falling objects:** The safeguard should ensure that no objects can fall into moving parts.
4. **Create no new hazards:** A safeguard defeats its own purpose if it creates a hazard such as a shear point, a jagged edge, or an unfinished surface that could cause a laceration.
5. **Create no interference:** Any safeguard that impedes an operator from performing the job quickly and comfortably might soon be overridden or disregarded.
6. **Allow safe lubrication:** If possible, workers should be able to lubricate the machine without removing the safeguards.

Protective Clothing and Personal Protective Equipment

Not all rotating motion can be completely eliminated or guarded. Gloves, loose-fitting shirts, loose long hair, and/or jewelry that could become entangled in rotating spindles or other kinds of moving machinery are not permitted around equipment.

Training

The best safeguarding system cannot offer effective protection unless the operator knows how to use it and why. Specific and detailed training is therefore a crucial part of any effort to provide safeguarding against machine-related

hazards. Any person who works near or adjacent to, any sort of machine should receive training during initial orientation and every two years thereafter. Employees performing maintenance related activities should receive machine guarding training on an annual basis.

Operator training should include hands-on training in the following:

- A description and identification of the hazards associated with the operator's machine(s)
- How the safeguards provide protection and the hazards for which they are intended
- How to use the safeguards and why
- How and under what circumstances safeguards can be removed, and by whom (in most cases, repair or maintenance personnel only)

Additional training should be provided when any new or altered safeguards are put in service, or when operators are assigned to a new machine or operation.

Roles & Responsibilities

It is Management's Responsibility to:

- Ensure machines are equipped with appropriate safeguards.
- Provide personal protective equipment to operators, when necessary.
- Provide machine specific training to operators.
- Provide periodic audits of machine guarding.

It is Supervisor's Responsibility to:

- Ensure operators do not defeat machine safeguards.

It is **ALL** Employees' Responsibility to:

- Only operate machines with all safeguards in place.
- Immediately report a safeguard that is damaged, missing, or unable to provide adequate protection to your supervisor.
- Remove gloves, loose-fitting shirts, and jewelry and tie back long hair when working around moving machinery.

For further information of assistance, contact your Zenith Safety & Health consultant.

Zenith provides workplace safety resources at: **TheZenith.com**

RM145FOOD 3

Zenith Insurance Company (Zenith) assists employers in evaluating workplace safety exposures. Surveys and related services may not reveal every hazard, exposure and/or violation of safety practices. Inspections by Zenith do not result in any warranty that the workplace, operations, machinery, appliances or equipment are safe or in compliance with applicable regulations. Any recommendations and related services are not and should not be construed as legal advice or be used as a substitute for legal advice. Employee protection is ultimately the responsibility of the employer. Policy coverage is not contingent upon the provision, efficacy or sufficiency of these services.